



Reservdelista  
Spare Part List  
Ersatzteilliste

**30 mm M Flex**



---

## 7 Reservdelar

### 7.1 Spindelhuvud - Drill head - Bohrkopf

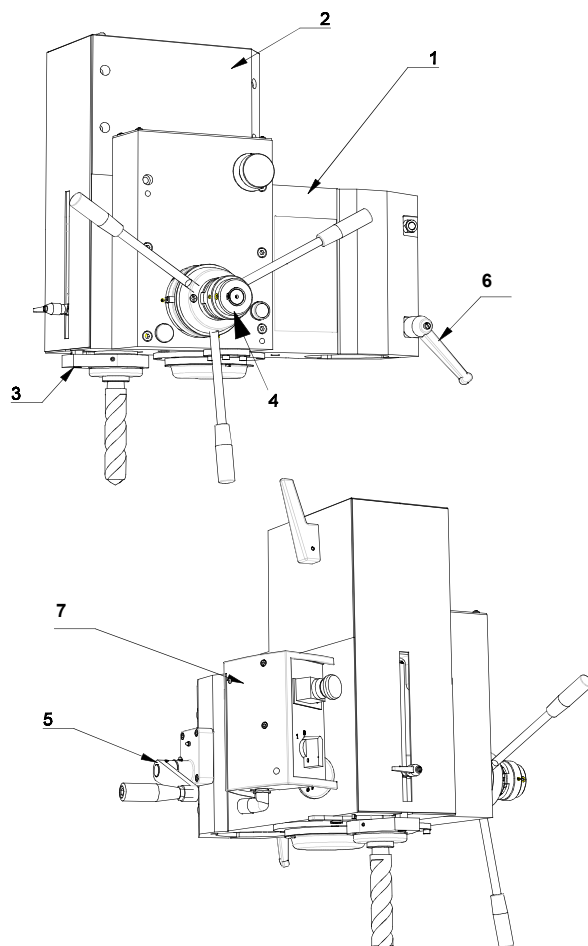

Pos	Article no.	Benämning	Description	Benennung	Not
1	2V08522-1	Spindelhus	Spindle housing	Spindelgehäuse	
2	2X08516-F	Växellåda	Gear box	Getriebekasten	
3	2X08529R	Spindelhylsa	Spindle sleeve	Spindelhülse	
4	2I08456	Matningsaxel	Feed shaft complete	Vorschubwelle komp	
5	2X08720-1R	Snäckväxel	Worm gear unit	Schneckenwechsel	
6	3R00014-1	Ställbar låsspak	Lock handle	Schlossbügel	
7	2X40891	Elutrustning komplett	Electric equipment compl	Elektrische Geräte kompl.	

---

## 7.2 Växellåda - Gear box - Getriebegehäuse

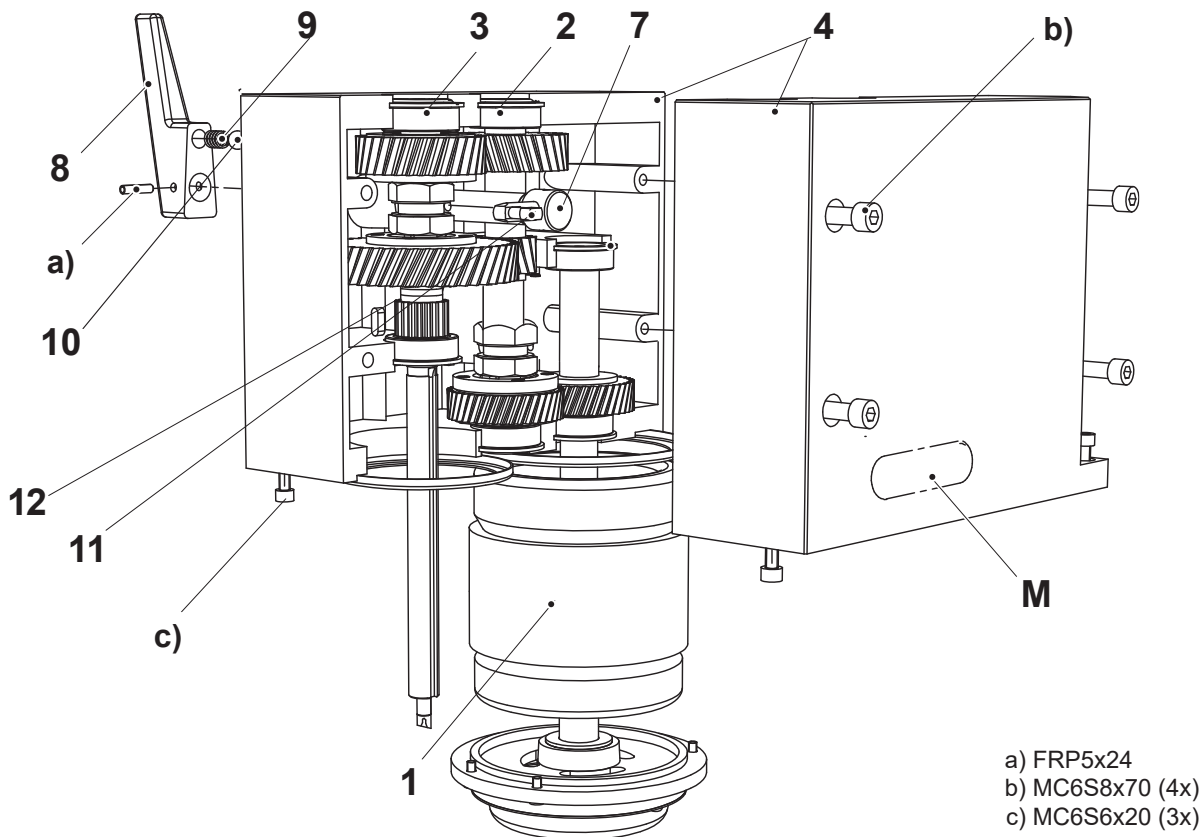

Pos	Artikelnummer	Benämning	Description	Benennung	Not
1	2X08566	Motoraxel komplett	Motor shaft complete	Motorwelle komplett	
2	2X08571R	2:a axel komplett	2:nd shaft complete	2:e Welle komplett	
3	2X08581R	3:e axel komplett	3:rd shaft complete	3:e Welle komplett	
4	2X08523-3	Växellådshus komplett	Gear box complete	Getriebekasten kompl.	
5	4B00174	Styrring	Ring	Ring	
7	2X08536	Skiftarm	Gear selector arm	Schaltarm	
8	2RS0653-1	Växelspak	Gear lever	Schalthebel	Kompl. 2XS0653-1
9	4C02921	Fjäder	Gear	Feder	
10	3T04028	Stålkula	Steel ball	Schaltgriff	
11	4T04168	Skiftstift	Shift pin	Stift	
12	3E08906	Induktiv givare	Inductive transmitter	Induktivgebergerät	

## 7.3 Motoraxel - Engine shaft - Motorwelle

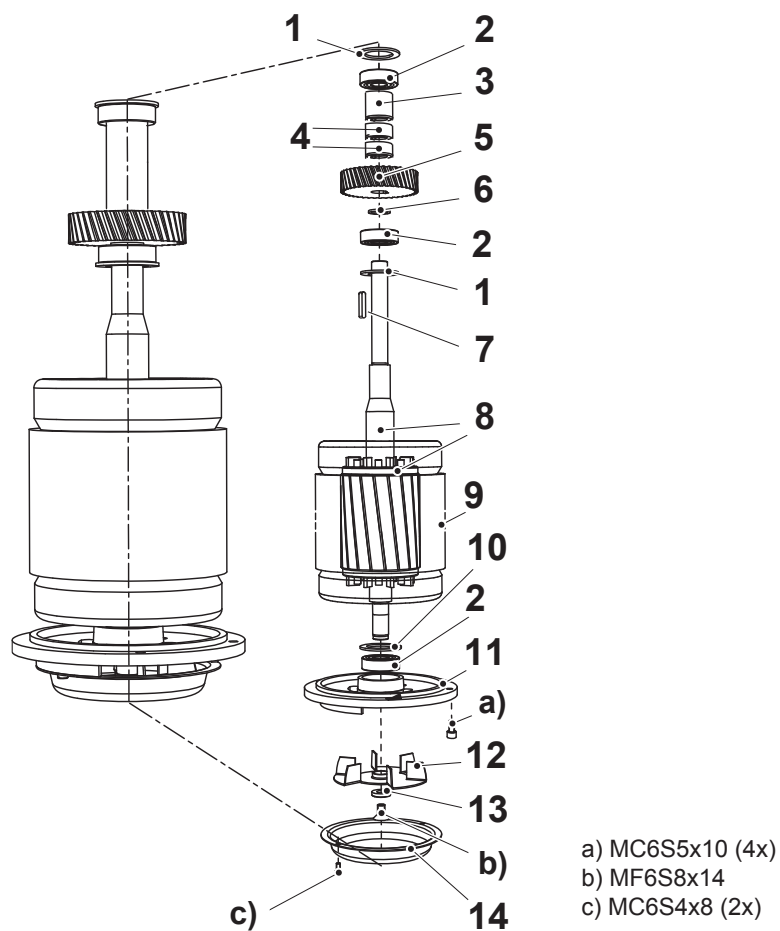

Pos	Artikelnummer	Benämning	Description	Benennung	Not
1	4B00137	Bricka	Washer	Scheibe	2x
2	3L15003	Kullager	Ball bearing	Kugellager	6203-2RS (3x)
3	2D00006	Distanshylsa	Spacing sleeve	Distanzhülse	17x31,5
4	2D17014	Distanshylsa	Spacing sleeve	Distanzhülse	17x14 (2x)
5	2H08563	Kugghjul	Gear	Zahnrad	40-2
6	2D00008	Distanshylsa	Spacing sleeve	Distanzhülse	17x6,5
7	3K01184	Kil	Key	Keil	RK 5x5x14
8	4X08532-1	Motoraxel med rotor	Shaft with rotor	Motorwelle mit Rotor	
9	3E81092	Stator SHb 130/100-4/K	Stator SHb 130/100-4/K	Stator SHb 130/100-4/K	400 - 440 V
10	4F06203	Bricka	Washer	Scheibe	
11	2N01889	Lagerlock	Bearing cover	Lagerdeckel	
12	4B00175	Vinghjul	Fan	Ventilator	
13	2B03449	Bricka	Washer	Scheibe	
14	4B01890	Flätkåpa	Fan cover	Ventilatordeckel	

## 7.4 2:a axel - 2:nd shaft - 2:e Welle

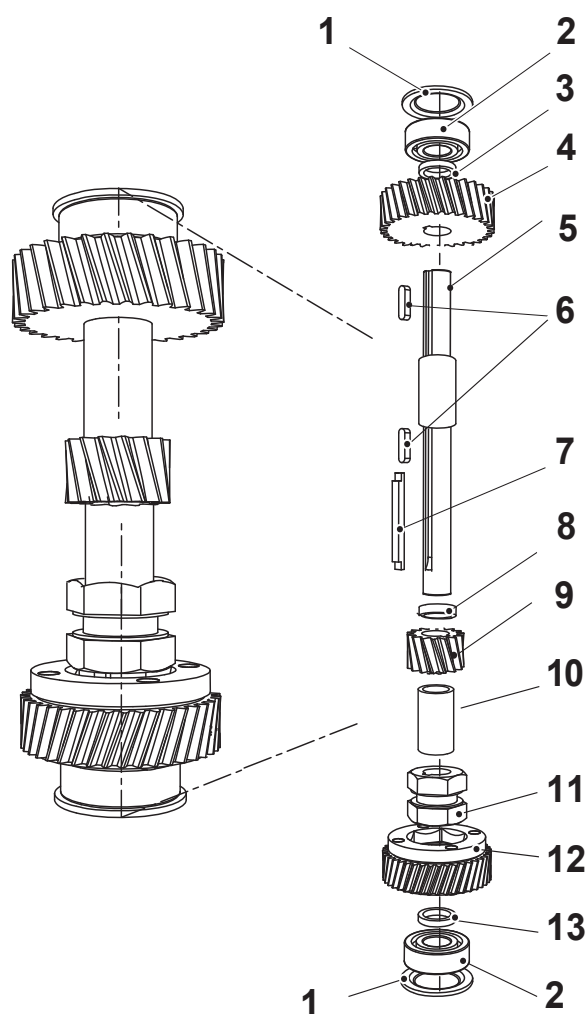

Pos	Artikelnummer	Benämning	Description	Benennung	Not
1	4B00138	Lock	Cover	Scheibe	2x
2	3L15003	Enrad spårkullager	Ball bearing	Kugellager	6203-2RS (2x)
3	2D00002	Distanshylsa	Spacing sleeve	Distanzhülse	17x2,5
4	2H08572	Kuggjul	Gear	Zahnrad	34-2
5	2A04871	2:a axel	2:nd shaft	2:e Welle	C-4871
6	3K01187	Kil	Key	Keil	RK 5x5x20 (2x)
7	2T06616	Övre kil	Key	Keil	
8	3B11005	Bricka	Washer	Scheibe	47x37x0,5
9	2H08573	Kuggjul	Gear	Zahnrad	15-2
10	2D17038	Distanshylsa	Spacing sleeve	Distanzhülse	17x38
11	2T04254	Kopplingsklo	Clutch	Kupplung	C-4254
12	2X08575R	Kuggjul kompl.	Gear compl.	Zahnrad kompl.	33-2 (fiber)
13	2D00008	Distanshylsa	Spacing sleeve	Distanzhülse	17x6,5

## 7.5 3:e axel - 3:rd shaft - 3:e Welle

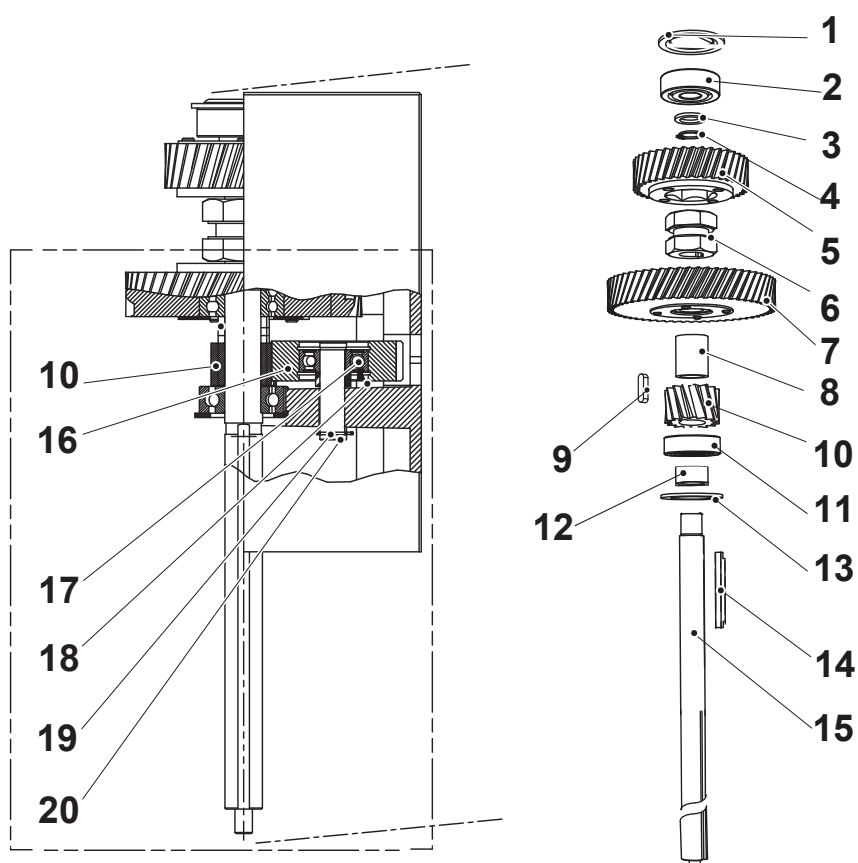

Pos	Artikelnummer	Benämning	Description	Benennung	Not
1	4B08584	Lock	Cover	Deckel	C-138
2	3L15002	Enrad spårkullager	Ball bearing	Kugellager	6302
3	3B01184	Bricka	Ring	Ring	15x22x1
4	3C01117	Spårring	Circlip	Führungsring	SgA 15
5	2X08582R	Kuggghjul kompl.	Gear compl.	Zahnrad kompl.	39-2 (fiber)
6	2T04254	Kopplingsklo	Clutch	Kupplung	C 4254
7	2X08583R	Kuggghjul kompl.	Gear compl.	Zahnrad kompl.	58-2 (fiber)
8	2D00007	Distanshylsa	Spacing sleeve	Distanzhülse	17x28,5
9	3K01186	Kil	Key	Keil	RKh9 5x5x18
10	2HSB7501-2	Kuggghjul	Gear wheel	Zahnrad	18-1,5
11	3L15003	Enrad spårkullager	Ball bearing	Kugellager	6203-2RS
12	2D17019	Distanshylsa	Spacer	Distanzhülse	17x19
13	4B00137	Lock	Cover	Deckel	C-137
14	2T06615	Övre kil	Key	Keil	C-6615
15	2A08531	Spindelförlängning	Spindle shaft	Spindelwelle	
16	2X08558	Mellanhjul kompl.	Gear complete feed	Zahnrad Vorschub	
17	3L13001	Kullager	Bearing	Kugellager	6201 2Z
18	2D12017	Distanshylsa	Spacer	Distanzhülse	12x17
19	3C01114	Spårring	Circlip	Sicherungsring	SGA 12 (2x)
20	2A08548	Axel till mellanhjul	Feed gear shaft	Welle Vors. Zahnrad	

## 7.6 Spindelhylsa - Spindle sleeve - Spindelhülse

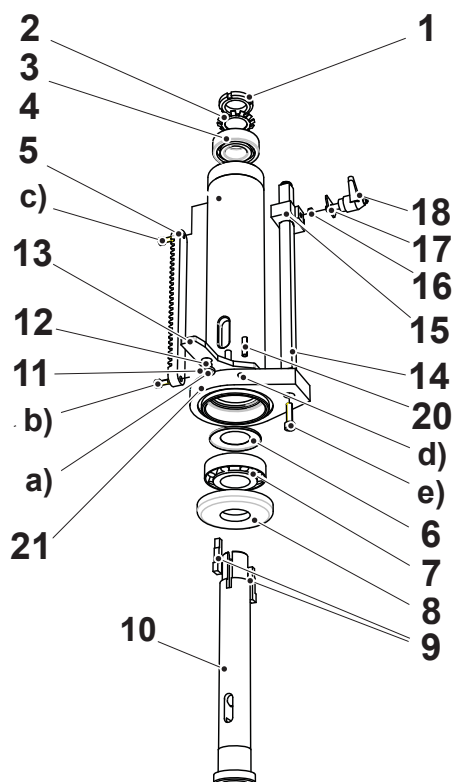

- a) MF6S5x20
- b) MC6S5x10 + FBB 5.1
- c) MC6LS5x10 + FBB 5.1
- d) SK6SS 6x8 (3x)
- e) MC6S6x20 Esloc

Pos	Artikelnummer	Benämning	Description	Benennung	Not
	2X08529R	Spindelhylsa kompl.	Spindle sleeve compl.	Spindelhülse kompl.	
1	3M06005	Mutter	Nut	Mutter	KM5
2	3B07005	Låsbricka	Locking washer	Sicherungsscheibe	
3	3L15005	Kullager	Ball bearing	Kugellager	6205
4	2G08529	Spindelhylsa	Quill	Spindelhülse	
5	4I08754	Kuggstång	Rack	Zahnstange	
6	4B03769	Bricka	Washer	Scheibe	
7	3L51006	Koniskt rullager	Taper roll bearing	Rollenlager, konisch	30206
8	2TS2019	Lagerlock	Bearing cover	Lagerdeckel	
9	2T08518	Kil till borrarspindel	Key for spindle	Keil für Spindel	
10	2A08517R	Borrarspindel	Spindle	Bohrspindel	MK3
11	3B06003	Avkupaad bricka	Washer	Scheibe	10,5x18x0,8
12	2T08593	Distanshylsa f. anslag	Spacer	Hülse	
13	4T08547	Anslag f. utstötare	Drill ejector lever	Anschlag	
14	2A08756-1R	Djupmåttstång	Depth gauge rod	Tiefenmass	
15	2T08759	Stopp f. matning	Stop	Tiefenmassanschlag	Kompl. 2X08759R
16	4CSB140046	Tryckfjäder	Spring	Feder	
17	4L08626	Visare	Indicator	Zeiger	
18	3R00003	Låsspak	Handle	Griff	43-M6x16
20	3P12308	Pinne	Pin	Stift	FRP 5x20
21	2N08551R	Ok	Quill collar	Spindeljoch	

## 7.7 Matningsaxel - Feed shaft - Vorschubwelle

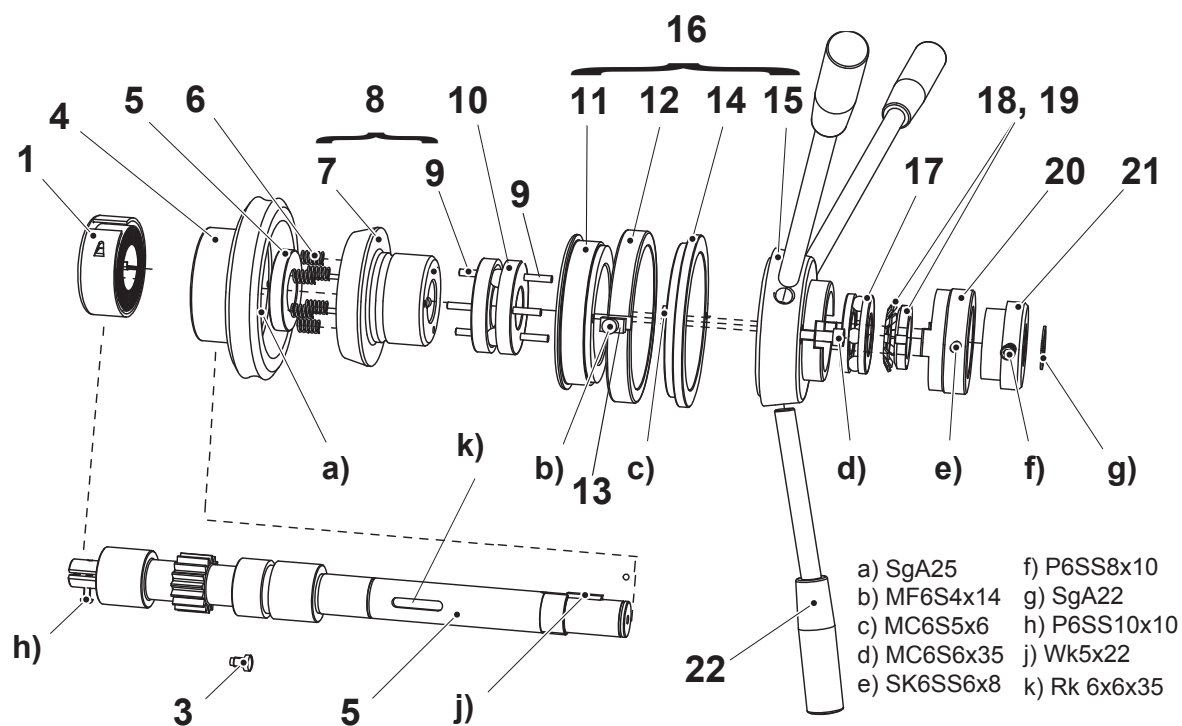

Pos	Artikelnummer	Benämning	Description	Benennung	Not
1	4XS2150R	Returfjäder	Return spring	Rückholfeder	
2	2I08456	Matningsaxel	Feed shaft	Vorschubwelle	
3	4S04211	Styrskruv	Guide screw	Führungsschraube	
4	2ISB7523-2	Snäckhjul	Worm wheel	Schneckenrad	
5	2TSB142081	Tryckplatta	Pressure plate	Druckscheibe	
6	4CSB548090-2	Tryckfjäder	Clutch head spring	Druckfeder	6x
7	2NSB142080	Kopplingshuvud	Clutch head	Kupplungskopf	
8	2XSB142080	Kopplingshuvud	Clutch head	Kupplungskopf	
9	3P07257	Stift	Pin	Stift	6x
10	2TSB548091R	Kopplingskiva med kuler	Clutch half with steelballs	Kupplungsscheibe mit kugeln	2x
11	2TSB548092	Låsring	Lock ring	Schliessring	
12	2TSB548093-1	Anslagsring	Stop ring	Stoppring	
13	2TSB548093-3	Anslagsklack	Stop	Anschlag	
14	2TSB548093-2	Ställring	Adjusting ring	Einstellring	
15	2TSB548094-1	Handspaksfäste	Handle holder	Griffhalter	
16	2XSB548094	Handspaksfäste kompl.	Handle holder compl.	Griffhalter kompl.	
17	3L61005	Axialkullager	Bearing	Lager	
18	3B07005	Låsbricka	Locking washer	Blechsicherung	
19	3M06005	Mutter	Nut	Mutter	
20	2TSB548096-1	Klokoppling	Coupling clutch	Klauenkupplung	
21	2TSB548096-2	Nav för klokoppling	Coupling hub	Kupplungsnav	
22	4E08758R	Handspak	Feed lever	Vorschubhebel	3x

## 7.8 Matn.växellåda - Power feed box - Vorschubgetriebe

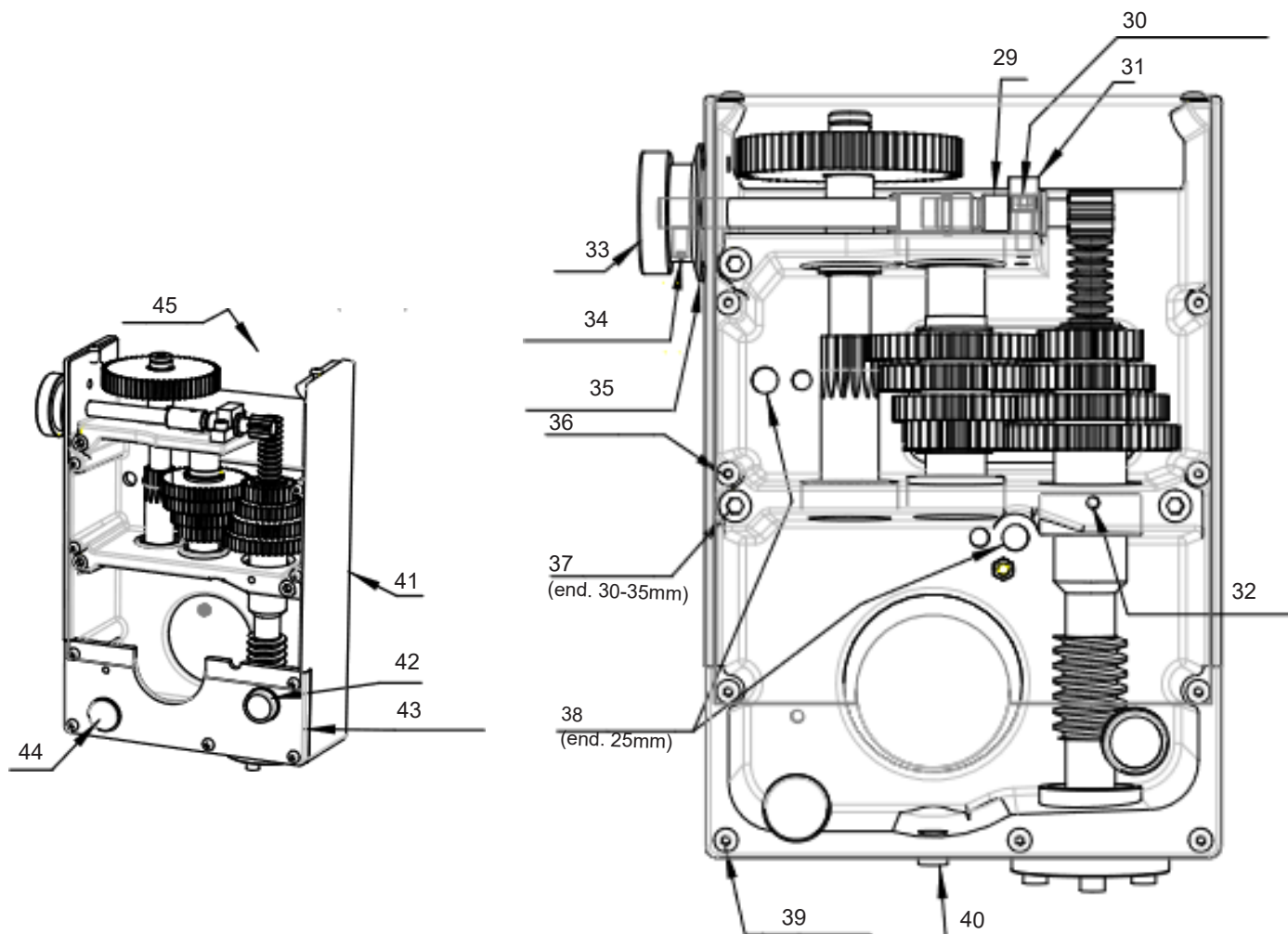
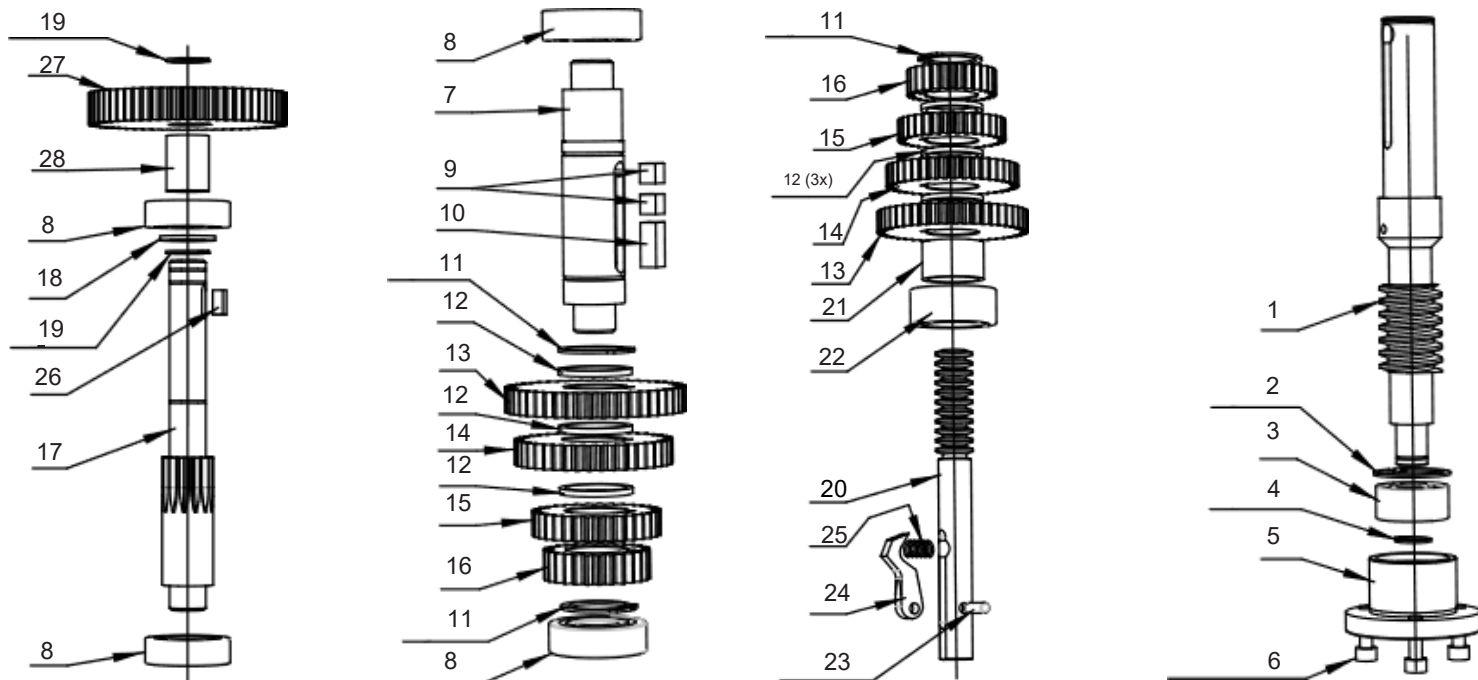

Pos	Artikelnummer	Benämning	Description	Benennung	Not
1	2I08639	Snäckskruv matn.låda	Worm shaft feed box	Schneckewelle Vorsch.	
2	3C02133	Spårring	Circlip	Sicherungsring	SGH 35
3	3L40002	Tvårad. vinkelkontaktl.	Bearing	Lager	3202
4	3C01117	Spårring	Circlip	Sicherungsring	SGH 15
5	2T08555	Lagerhus	Bearing housing	Lagergehäuse	
6	3S03370	Skruv	Screw	Schraube	MC6S 6x20 (3x)
7	2A08541	Axel till matning	Feed shaft	Vorschubwelle	
8	3L15003	Kullager	Bearing	Kugellager	6203-2RS (4x)
9	3K00934	Kil	Key	Keil	TK 8x7x8 (2x)
10	3K00294	Kil	Key	Keil	TK 8x7x18 h9
11	3C01126	Spårring	Circlip	Sicherungsring	SGA 25
12	2B03150	Bricka	Washer	Scheibe	(6x)
13	4H08556-7	Kuggghjul	Gear wheel	Zahnrad	47-1,5 (2x)
14	4H08556-6	Kuggghjul	Gear wheel	Zahnrad	41-1,5 (2x)
15	4H08556-5	Kuggghjul	Gear wheel	Zahnrad	33-1,5 (2x)
16	4H08556-4	Kuggghjul	Gear wheel	Zahnrad	27-1,5 (2x)
17	2I08540	Kuggaxel .	Gear shaft	Zahnwelle	
18	2D17002	Distanshylsa	Spacer	Distanzhülse	17x2
19	3C01119	Spårring	Circlip	Sicherungsring	SGA 17 (2x)
20	2I08649	Axel matn.växellåda	Shaft feed gear box	Welle Vorschubgetr.	
21	4DSB7530-2	Distansring	Spacer	Distanzring	25x18
22	3L00010	Nållager	Needle bearing	Nadellager	NA 4905
23	3P01307	Pinne	Pin	Stift	CP 5x14
24	2TSB7534	Kil matningslåda	Key	Keil	
25	4CSB11750	Tryckfjäder	Spring	Feder	
26	3K00183	Kil	Key	Keil	TK 5x5x12
27	2HSB7546	Kuggghjul	Gear	Zahnrad	60-1,5
28	2D00005	Distanshylsa	Spacer	Distanzhülse	17x26,5
29	2I08542-1	Inställningsdrev	Gear shaft	Zahnwelle	
30	3S03372	Skruv	Screw	Schraube	MC6S 6x25
31	2N08457	Lagerbock	Bearing bracket	Lagerbock	
32	3S07366	Låsskruv	Screw	Schraube	S6SS 6x12
33	2X05431	Ratt	Hand wheel	Handrad	
34	3S04368	Skruv	Screw	Schraube	SK6SS 6x16
35	3C01114	Spårring	Circlip	Sicherungsring	SGA 12
36	3S24323	Skruv	Screw	Schraube	K6S 5x8 (6x)
37	3S03468	Skruv	Screw	Schraube	MC6S 8x85 (3x)
38	3S03491	Skruv	Screw	Schraube	MC6S 10x20 (2x)
39	3S24331	Skruv	Screw	Schraube	K6S 5x20 (5x)
40	3S50002	Oljeplogg	Plug	Propfen	R ¼"
41	4X08781	Matningsväxellåda	Feed gear box	Gehäuse	
42	3S50005	Oljepåfyllplogg	Oil fill plug	Ölfüllpropfen	
43	4N08781	Nedre lock	Cover	Deckel	
44	3T03002	Oljenivåglas	Oil sight glass	Ölstandglas	
45	4L08783	Övre lock	Cover	Deckel	

## 7.9 Pelare - Column - Säule

### 7.9.1 Pelarborrmaskin - Column drilling machine - Säulenbohrmaschine

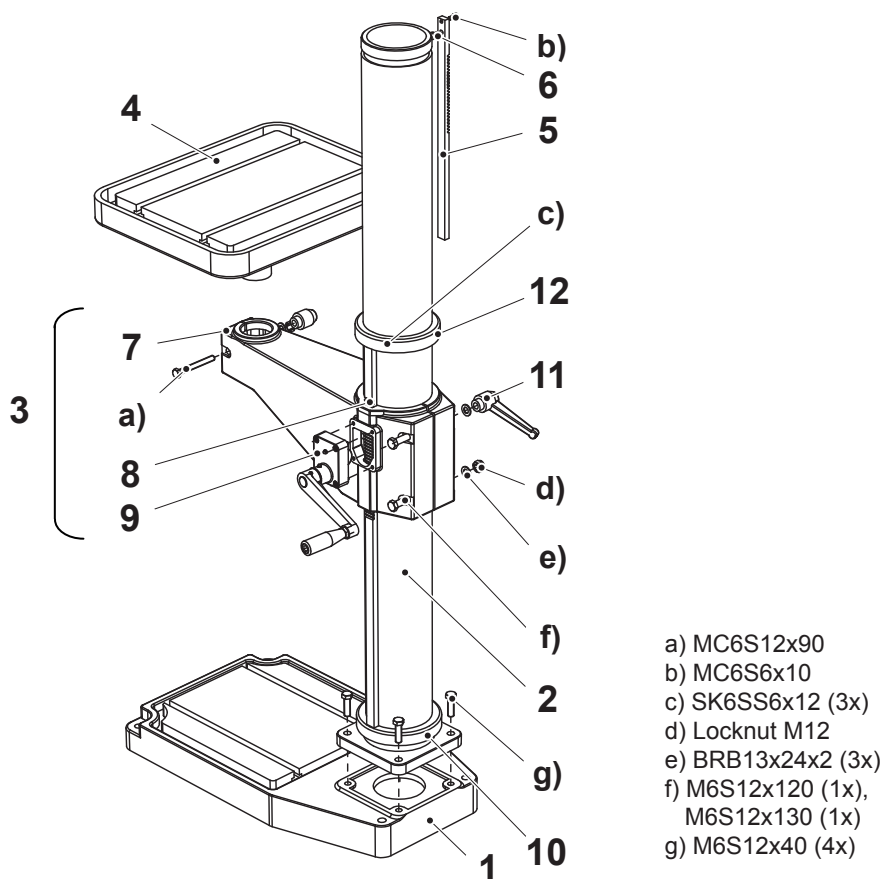

Pos	Artikelnummer	Benämning	Description	Benennung	Not
1	4W03040	Fotplatta	Base plate	Fussplatte	
2	9X08543	Pelare	Column	Säule	
3	2X08730R	Bordarm kompl.	Table arm compl.	Tischarm kompl.	
4	2X07842R	Fyrkantbord kompl.	Table compl.	Tisch kompl.	500x400
5	2X08445	Kuggstång	Rack	Zahnstange	
6	2T07146	Tapp	Pin	Zapf	
7	2Y08730	Bordarm	Table arm	Tischarm	
8	4I03598	Kuggstång bordarm	Rack table arm	Zahnstange Tischarm	
9	2X08720-1R	Snäckväxel kompl.	Worm gear compl.	Schneckengetriebe kompl.	
10	2N08568R	Nedre ring	Lower ring	Unterer Ring	
11	3R00014-1	Låsspak	Lock handle	Schlossbügel	GN300 S108-M12
12	2N08567R	Övre ring	Upper ring	Oberer Ring	

## 7.9.2 Bänkbormaskin - Column bench type drill - Tischbohrmaschine

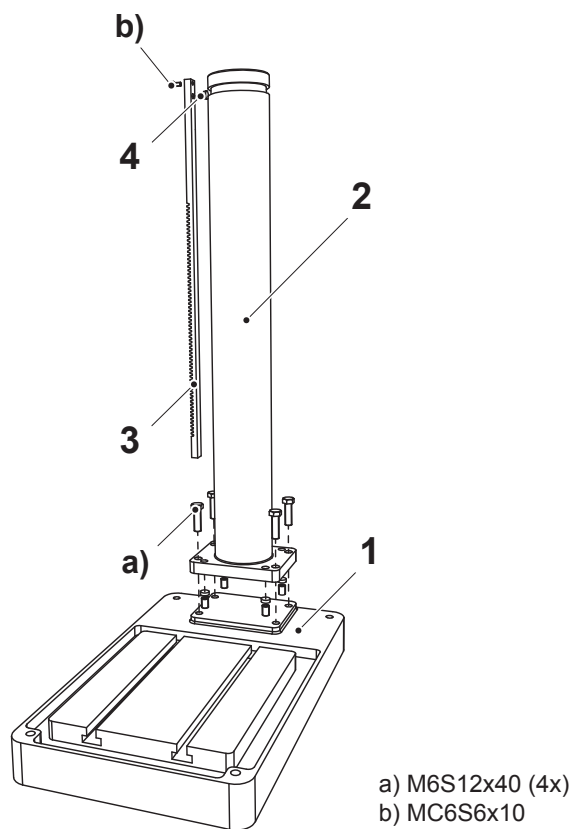

Pos	Artikelnummer	Benämning	Description	Benennung	Not
1	4W03040	Bänkplatta	Base plate	Fussplatte	
2	4X08543-1	Bänkelare	Column	Säule	
3	2X08545	Kuggstång	Rack	Zahnstange	
4	2T07146	Tapp	Pin	Zapfen	

## 7.10 Snäckväxelhus komplett - Worm gear box complete - Schneckengetriebegehäuse komplett

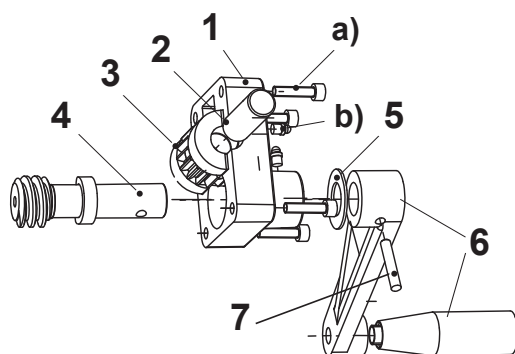
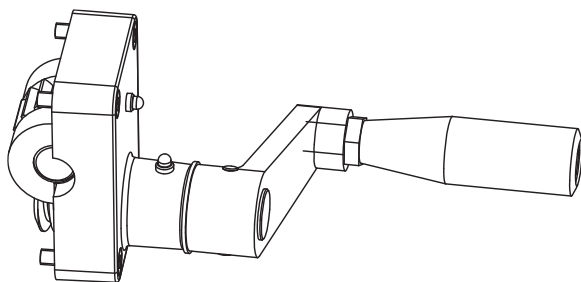

a) MC6S6x25 (4x)  
b) Lub.nipple Ø6 (2x)

Pos	Artikelnummer	Benämning	Description	Benennung	Not
1	2N08720R	Snäckväxelhus	Worm gear box	Schneckengetriebegehäuse	
2	2A08725	Axel	Shaft	Welle	
3	4HS1201	Kugghjul	Gear	Zahnrad	
4	2IS1203-2	Snäckskruv	Worm shaft	Schneckenwelle	
5	3L00027 3L00025 3L00028	Axialbricka Axialnålrollager Vågbricka	Washer	Scheibe	AS 2035 AXK 2035 EPO 20 EMO
6	3R01182	Vev kompl. m. handtag	Crank compl. with handle	Kurbel kompl. mit griff	
7	3P06035	Spännstift	Pin	Stift	

## 7.11 Elbox - Electric box - Elektrokasten

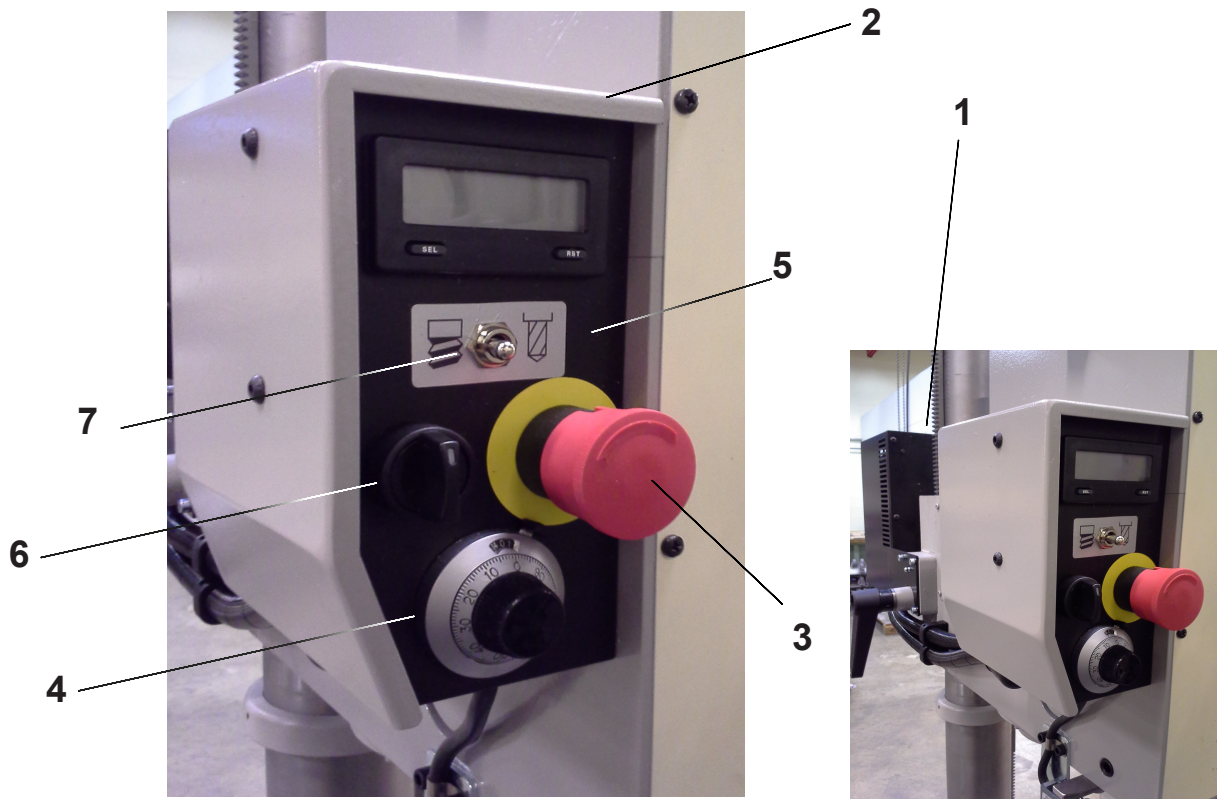

Pos	Art. no.	Benämning	Description	Benennung	Not
	2X40891	Elutrustning komplett	Electric equipment compl.	Elektrische Geräte kompl.	
1		Frekvensomriktare	Inverter	Frequenzumrichter	
2	4U08791	Elboxkåpa	Electric box cover	Elektrokastengehäuse	
3		Nödstoppknapp	Emergency stop	Notstopp	
4		Potentiometer	Potentiometer	Potentiometer	
5	4L08796	Elboxpanel	Electric box plate	Elektrokastenschild	
6		Start/stopp	Start/stopp	Start/stopp	
7		Borrning/gängning	Drilling/tapping	Bohr/Gewinde	



## Machinery Scandinavia AB

Tel +46 49549700

### Företag / kund

Projektbeskrivning

30 M FLEX

Ritningsnummer

1772-4 A

Kommission

Machinery Scandinavia AB

Tillverkare (företag)

Machinery Scandinavia AB

Fält

Projektnamn

1772 Machinery Scandinavia

Fabrikat

Typ

Installationsplats

Projektansvarig

Delegenskap

Skapad den

2016-08-24

Redigerad den

2020-01-21

från (förkortning) babpereri

Antal sidor 5

		=		=A1 +KA1/1	
		+			
		Ritn. nr:		1	
		Blad		1	
		Blad tot:		5	
		Titel- / försättsblad			
					
		Machinery Scandinavia AB			
		30 M FLEX			
		Ersättning för		Ersatt av	
Datum		2020-01-13			
Redigerare		babpereri			
Kontrollerad					
Ursprung					
Datum					
Namn					

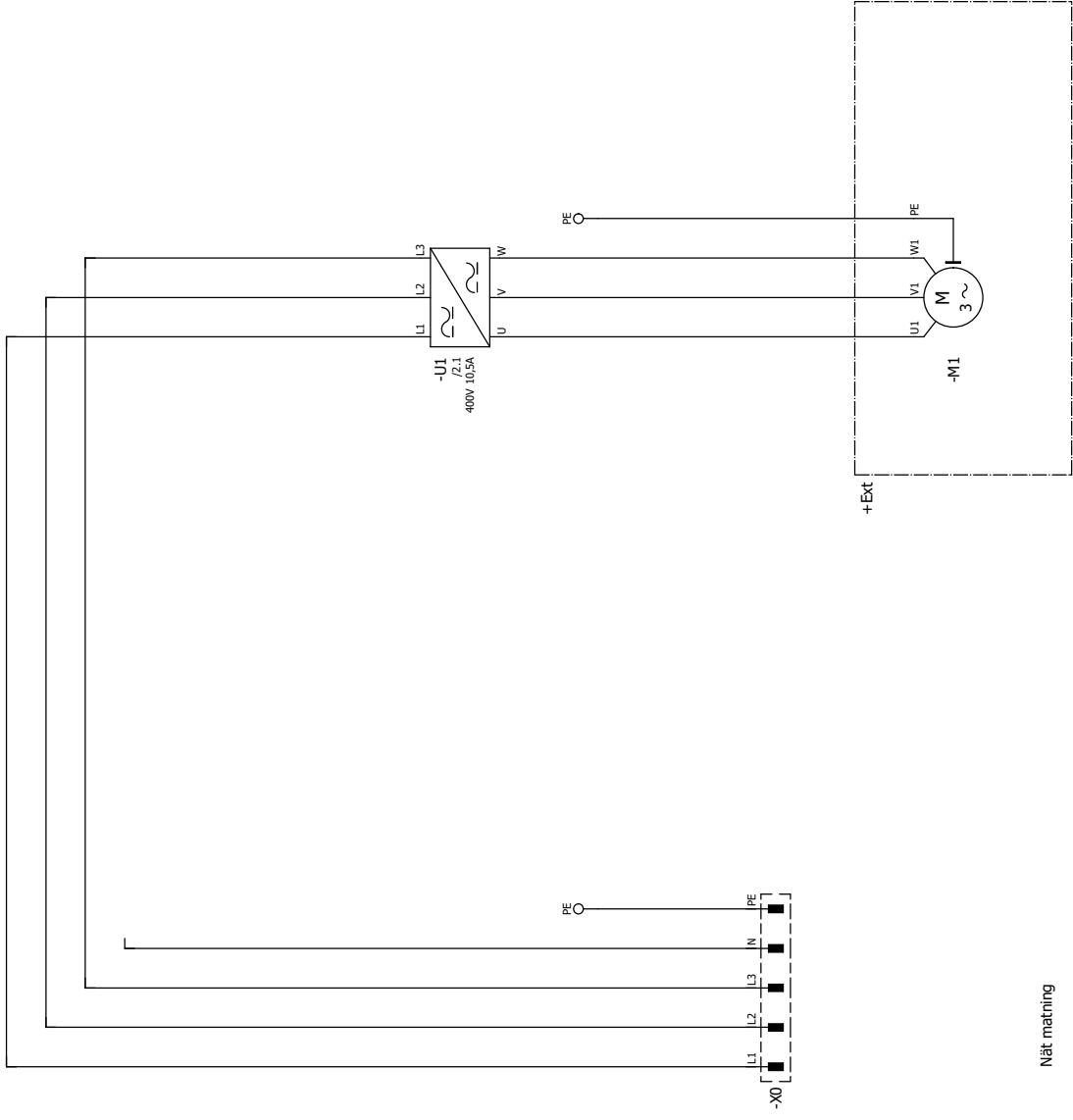

Nät matning

= +/1		2	
Ändring	Datum	Kraft fördelning	
	2020-01-16	= A1 + KAI	
	Redigerare ballefnyg	Ritn. nr. 1772-4 A	
	Kontrollerad	Blad 1	
	Ursprung	Blad tot. 5	
	Namn	Ersättning för	
		Ersätt av	
		Machinery Scandinavia AB	
		30 M FLEX	
		Ersättning för	
		Ersätt av	





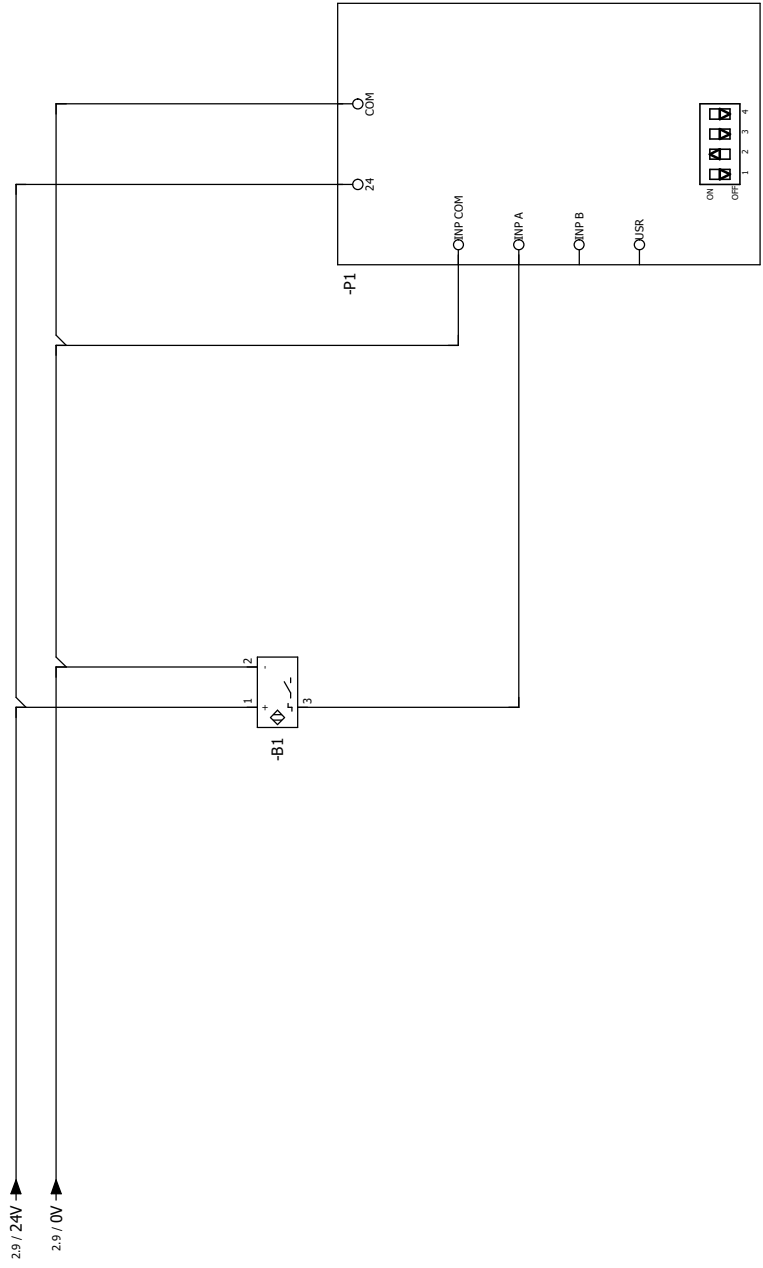

Varvtaalsmätare



Machinery Scandinavia AB  
30 M FLEX  
Ersättning för

Datum	2020-01-21
Redigerare	batipateri
Kontrollerad	
Ursprung	

Datum	
Namn	

Ersatt av



