



ROSENFORS

MADE IN SWEDEN



User Manual

EN English

SE Svenska

Gratulerar till ditt köp av en äkta svenskbyggd bormaskin. Vi är stolta över att vi kan märka våra maskiner med "Made in Sweden". I Rosenfors har vi byggt bormaskiner sedan 1937.

Innan du installerar och börjar använda din nya maskin vill vi gärna att du besöker vår hemsida: www.mscab.se/downloads. Lösenord: 57797

Där ska du ladda ned:

1. Elritningar
2. Reservdelslistor
3. Extra manual om du behöver.

Sist men inte minst viktigt, läs igenom vår manual och lär dig känna din nya maskin. Lycka till med din nya maskin!

EN English

Congratulations on your purchase of a real Swedish built drill. We are proud that we can label our machines with "Made in Sweden". In Rosenfors, we have been building drilling machines since 1937.

Before you install and start using your new machine, we would like you to visit our website: www.mscab.se/downloads. Password: 57797

There you should download:

1. Electrical drawings
2. Spare parts list
3. If you need an extra manual.

Finally, read the manual and get to know your new machine. Good luck with your new machine!

DE Deutsch

Herzlichen Glückwunsch zum Kauf einer in Schweden gebauten Bohrmaschine. Wir sind stolz darauf, dass wir unsere Maschinen mit "Made in Sweden" kennzeichnen können. In Rosenfors bauen wir seit 1937 Bohrmaschinen.

Bevor Sie Ihren neuen Bohrmaschine installieren und verwenden, möchten wir Sie bitten, unsere Website www.mscab.se/downloads zu besuchen. Passwort: 57797

Dort sollten Sie herunterladen:

1. Elektrische Zeichnungen
2. Ersatzteilliste
3. Zusätzliches Handbuch, wenn Sie brauchen

Lesen Sie abschließend das Handbuch und lernen Sie Ihre neue Maschine kennen. Viel Glück mit Ihrer neuen Maschine!

Table of Contents

Table of Contents

1. GENERAL	3
1.1 Guarantee	3
1.2 CE-labelling and Declaration of Conformity	3
1.3 Safety	3
1.3.1 Safety messages	3
1.3.2 Safety regulations	3
2. Design and function	6
2.1 Drill head	7
2.1.1 Manual feed	7
3. Installation	8
3.1 Set-up	8
3.2 Electric installation	8
4. Handling	9
4.1 Manual feed	9
4.1.1 Drilling	9
4.1.2 Expeller wedge	10
5. Maintenance	10
5.1 Cleaning	10
5.2 Lubrication	10
5.2.1 Drill head	11
5.2.2 Worm gear box	11
5.3 Repair	11
6. Corrective maintenance	12
6.1 General	12
6.2 Adjust the taper bearing play	12
6.3 Counter balancing the spindle	13
6.4 Motor	13
6.5 Gearbox	13



EU DECLARATION OF CONFORMITY (EN)

Manufacturer:

Machinery Scandinavia AB
Tungatan 10,
577 97 Rosenfors, Sweden
Tel +46 (0)495 49700

Hereby declares at our own risk that:

Drilling machines manufactured by Machinery Scandinavia AB with serial numbers 415000 – 416999,
are in conformity with:

- DIRECTIVE 2006/42/EC OF THE EUROPEAN PARLIAMENT AND OF THE COUNCIL of 17 May 2006 on the approximation of the laws of the Member States relating to machinery;
- DIRECTIVE 2014/30/EC OF THE EUROPEAN PARLIAMENT AND OF THE COUNCIL of 29 March 2014 on the approximation of the laws of the Member States relating to electromagnetic compatibility;
- EUROPEAN STANDARD EN 12717 + A1:2009 Safety of machine tools – Drilling machines.

Magnus Gustavsson, CEO
Machinery Scandinavia AB

577 97 Rosenfors, Sweden

Rosenfors. 2023-03-01

Magnus Gustavsson

ARBOGA | STRANDS | SOLBERGA | IMA | ROSENFORS

MACHINERY SCANDINAVIA AB | 577 97 ROSENFORS | SWEDEN | tel +46 (0)495 49700
sales@mscab.se | www.mscab.se | Høgsby Sparbank | VAT No. SE556063541801

1. GENERAL

In this manual is presented all MSC drilling machines ranging from 25 to 35 mm. It has been prepared for those using the machine or who are responsible for its maintenance and service and should therefore be made readily available for all those concerned.

Read through the manual carefully before installing and starting up the machine. The machine is of simple design and robustly built, but we cannot guarantee perfect function if it is not correctly handled.

It is therefore necessary to make yourself thoroughly acquainted with its functions and to carry out practical tests on the various parts of the control system and the machine settings. Once these are mastered, the properties of the machine can be fully utilized and the component parts will give maximum service life.

Every machine is tested for accuracy and capacity at the factory. Experienced staff checks both the mechanical and electrical functions according to a standardized programme, meaning that we can guarantee workmanship of the highest and most consistent quality.

By following our directions and your own good judgement, we are convinced that your new machine will give you every satisfaction. However, should any problems arise, please do not hesitate to contact our dealer or us.

1.1 Guarantee

See the guarantee terms at our homepage "<http://www.msCab.com>".

1.2 CE-labelling and Declaration of Conformity

An "EC Declaration of Conformity" accompanies machines delivered within the European Union (CE-labelled machines).

The declaration of conformity is valid only if the chuck guard (see figure 2) is used.

1.3 Safety

1.3.1 Safety messages

Safety messages in this manual are accompanied by a safety alert symbol and a signal word. The safety alert symbol is used to alert the reader about a potential risk of personal injury or damage on the equipment.

1.3.2 Safety regulations

Used correctly, your machine is one of the best concerning design and safety. However, any machine which is used incorrectly can be a safety risk.

It is very important, that those who use the machine are informed how to handle it correctly. They should read and understand these instructions, as well as all signs on the machine. Neglecting to follow the safety regulations can cause an accident.



**Warning: Using the machine incorrectly can cause serious accidents.
The machine has to be installed, used and maintained correctly.**

All machines with rotating tools or details can cause accidents. It is therefore important that you as an operator are aware of those risks for any accident and that you avoid all possibilities for accidents.



Figure 1 - Warning symbols on the machine

- Always use appropriate clothes and personal equipment, so that you cannot get caught by rotating tools. Avoid using protective gloves if possible. Use hairnet if necessary.
- Always use eye protection, if there is a risk for chips or splashes from the coolant. Follow local instructions if existing.
- Never use the machine if it lacks necessary protection.
- The chuck guard (figure 2a) must always be used. For safety reasons, the chuck guard is equipped with a micro switch.

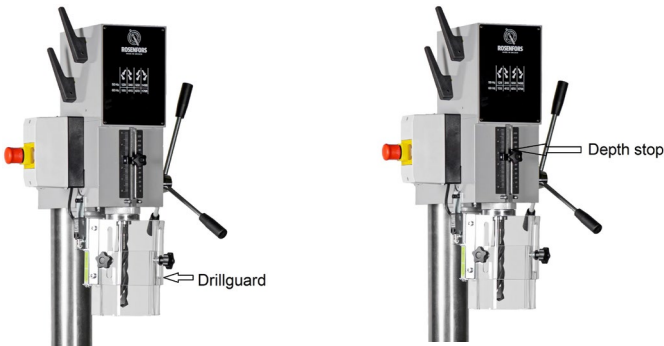

Figure 2a - Chuck guard (for machines within the EU). Figure 2b - Depth gauge (3).

- Depth gauge and Depth gauge rod (3) must never be removed from the machine.
- Keep clean around the machine to avoid stumbling against rotating tools.
- Make sure that the work piece is securely fastened at the table, see the examples in figure 3 and 4.



Warning: Never use your hand to hold the work piece.

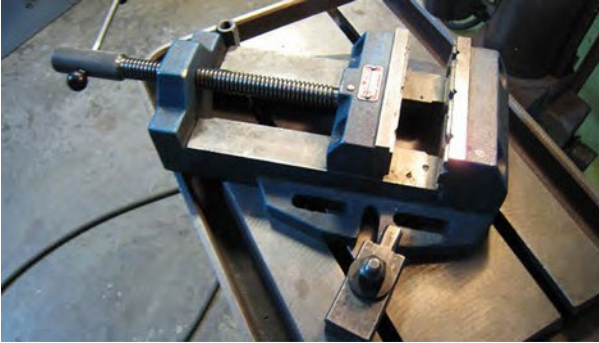

Figure 3 - Fastening the table vice on the table, example

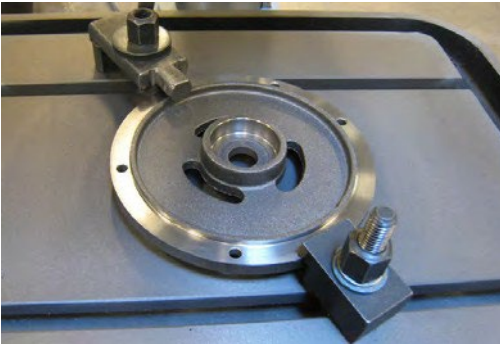

Figure 4 - Fastening the work piece on the table, example

- Make sure that the switch is in position “0” when changing tools or when cleaning the machine. Never brush away chips while the machine is operating.
- Never stretch yourself over the machine when it is running.
- Always stop the machine when not in use.
- Use faultless tools and the correct speed and feed for the tool. Make sure that the tool is the correct one for you operation.
- Make sure that the drill head, table arm and table are thoroughly fastened before starting up the machine.

2. Design and function

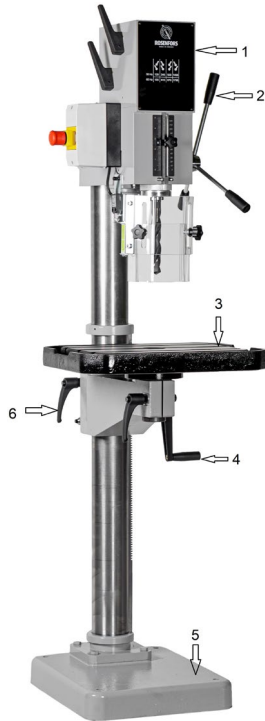

Figure 5 - Drilling machines

1. Drill head
2. Feed shaft with handle
3. Table
4. Crank for worm gear (1 pcs)
5. Base plate
6. Lock handle (2 pcs)

The gearbox is built according to our experienced methods for highest possible torque. Gears in the main gear box ensure higher operation efficiency, a more powerful drive mechanism and smooth operation.

Table and the table arm are adjustable 360° around the column and can be raised and lowered.

2.1 Drill head

2.1.1 Manual feed

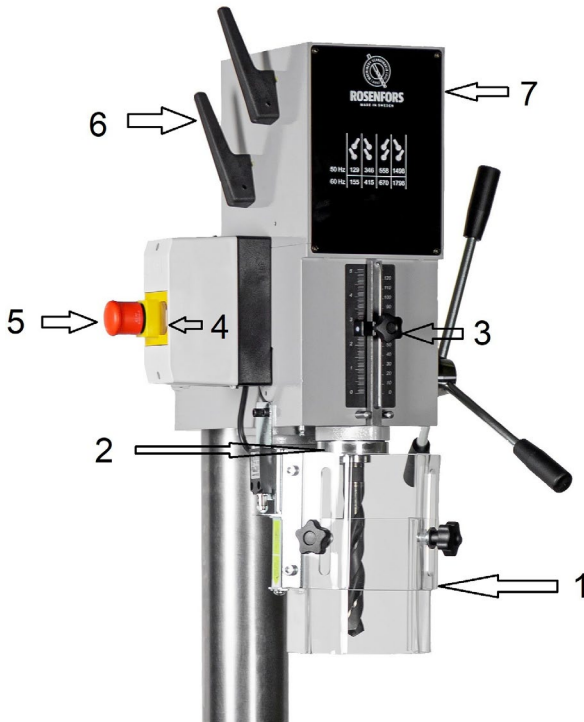

Figure 6 - Drill head, example

1. Chuck guard
2. Spindle quill
3. Depth gauge rod
4. Start button
5. Emergency stop push button
6. Gear lever (2 pcs)
7. Gearbox

Emergency stop

See the location of the emergency stop push button in figure 6 (position 5). The emergency stop shall be used in case of emergency stop to stop the machine as fast as possible. It is also used to stop the machine.

3. Installation

3.1 Set-up

Consider the following during set-up of the machine:

- The machine must be installed on a firm foundation. The base plate must be levelled with washers on the foundation bolts, to prevent harmful stresses when the nuts are tightened.
- Do not install the machine in a humid, dirty or badly illuminated environment.
- All bright parts of the machine are treated with rust prevention. By removing this, be careful not to use too strong cleaning compound. The paint might then get damaged.
- Make sure that the boring tool cone is well-cleaned.
- Be sure that the machine is equipped with all necessary protections to comply with the CE directives.
- For machines with automatic feed, the gear box must be filled up with oil, see chapter “5.1 Oil filling, feed gear box” on page 21.

3.2 Electric installation

Note! Electric installations have to be performed by a qualified electrician.

1. Make sure that the correct voltage is supplied to the machine.
2. Set up the electrical connections according to the attached circuit diagram.
3. Make sure that the drilling spindle has the correct rotation direction.

4. Handling

4.1 Manual feed



Warning: Use the lock handles to lock the drill head, table arm and the table. Make sure that the work piece is securely fastened at the table. Carefully read through the safety instructions in this manual before using the machine.

4.1.1 Drilling

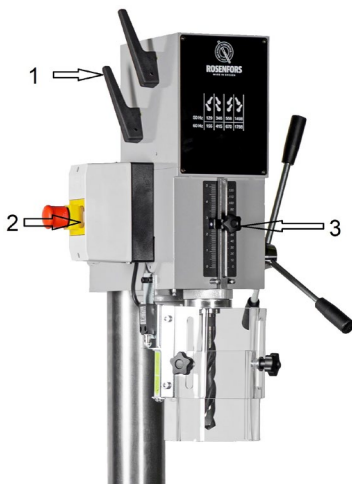

Figure 9 - Set-up

See figure 9.

1. The machine is equipped with a 1-speed motor. Select the spindle speed using the two gear levers (1) on the left side of the gearbox (see the sign on the front side of the machine). If any of the gears is difficult to get into position, rotate the spindle nose manually.

Note! The machine can not be shifted during operations.

Press the button 2 to start the machine.

3. Feed the spindle down to the desired drill depth.
4. Set the stop on the depth gauge rod (3) in the desired position or else, set the stop in the upper position.

4.1.2 Expeller wedge

The boring tool may become stuck in the spindle, e.g. via hard drilling pressure and heat changes in the spindle. In this case, we recommend using an expeller wedge instead of the automatic drill ejector, see figure 15.



Figure 15 - Expeller wedge

5. Maintenance

5.1 Cleaning

- Always make sure that the boring tool tongue and cone are well-cleaned and not damaged. This to avoid unnecessary wear and tear of the drilling spindle and/or the boring tool getting caught in the spindle.
- Keep the table and work piece free from chips. Use a brush, not compressed air.

5.2 Lubrication

All ball bearings and gear wheels are lubricated at the factory.
For other lubrication; check levels regularly and apply grease if necessary, see figure 17 and figure 18.

5.2.1 Drill head



Figure 17 - Grease nipples, drill head

5.2.2 Worm gear box

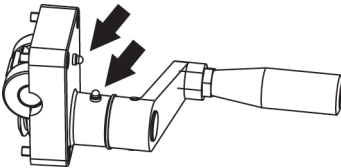

Figure 18 - Grease nipples, worm gear box

5.3 Repair

If your MSC drilling machine needs repair, contact your local retailer first and as a second option contact MSC.

6. Corrective maintenance

6.1 General



Warning: Disconnect the machine from the external mains before any dismantling takes place.

On reassembly, see to it that all surfaces are clean and that any burrs, which may have been made during disassembly, are first removed.

6.2 Adjust the taper bearing play

The spindle is journaled in the quill by a taper roller bearing at the bottom and by a radial ball bearing at the top. At the top end of the spindle, there is a nut, with which the play in the taper bearing can be adjusted. This nut can be reached, when the quill is removed from the machine as follows:

1. Remove the depth stop rod, see figure 19.



Figure 19 - Removing the depth stop rod

2. Feed out the complete quill with the feed handle. Hold the quill, so that it doesn't fall out and gets damaged.
3. Loosen the spring pressure by letting the feed handle slowly return.

4. Adjust the play at the top end of the quill by turning the nut clockwise. Make sure it does not turn heavily, see figure 20.



Figure 20 - Nut for adjusting the play of the quill

5. Turn the feed handle about two turns for counter balancing the quill.
6. Put back the quill and make sure the keys on the spindle coincide with the key ways in the spindle shaft and that the teeth of the feed shaft get the grip of the quill feed rack.
7. Let the quill return to the top position. Check the position of the feed handle and adjust by the feed shaft teeth grip another rack position.
8. If necessary, feed out the quill and turn the feed handle to further counter balance the quill as described in chapter “6.3 Counter balancing the spindle” on page 24.
9. Re-assemble the depth stop rod.

6.3 Counter balancing the spindle

Counter balance the spindle by tightening the spring in the spring housing as follows:

10. Remove the depth stop rod and feed out the complete quill, see chapter “6.2 Adjust the taper bearing play” on page 23.
11. Increase the return speed (the spring is tightened) by turning the feed handle 1/4 turn clockwise. Reduce the return speed by turning the feed handle 1/4 turn anti-clockwise.
12. Put back the quill and re-assemble the depth stop rod, see chapter “6.2 Adjust the taper bearing play” on page 23.

6.4 Motor

In case of motor failure, please contact Machinery Scandinavia for further information.

6.5 Gearbox

In case of gearbox failure, please contact Machinery Scandinavia for further information.

NOLLSPÄNNINGSUTLÖSARE NO-VOLT RELEASE COIL NULLSPANNUNGS AUSLÖSER	
3E10715	220/50 - 60
3E10712	380/50 - 440/60

MOTORSKYDD MOTOR STARTER SWITCH PROTECTOR MOTORSCHUTZSCHALTER	
3E10702	1,6-2,5A
3E10703	2,5-4,0A

3E10630	
Kapsling med nödstop	
Housing incl. Emergency stop button	
Gehäuse inkl. Notstop Taste	

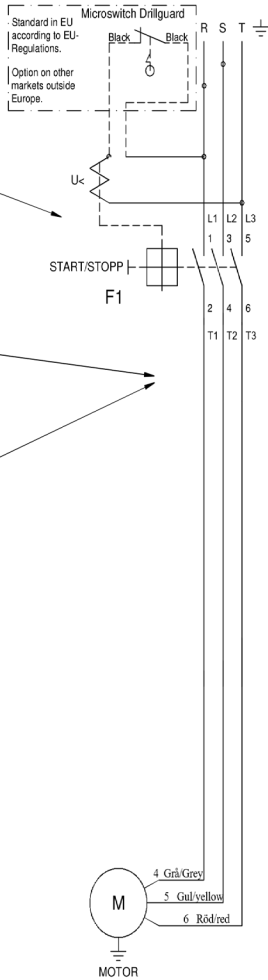

Copyright © 2020 Machinery Scandinavia AB



Machinery Scandinavia AB
SE - 577 97 Rosenfors, Sweden
Tel: +46 (0)495 497 00
sales@mscab.se
www.mscab.se